

Innovation Starts In The Lab

# Tekran<sup>®</sup> Series 2600-IVS

## Ultra-Trace Mercury Analysis System

- *Unsurpassed Analytical Performance*
- *Free Lifetime Technical & Analytical Support*
- *Low Maintenance & Easily Serviceable*
- *Fast, Flexible & Reliable Software*



Ultra Sensitive Measurement  
MDL 0.02 parts per trillion (ppt)

# A Superior Design Offers Unsurpassed Analytical Performance & Flexibility



The Tekran® Series 2600-IVS is the most stable, sensitive ultra-trace mercury analyzer available today.

The Series 2600-IVS was designed to be easy to set up, easy to use, and easy to maintain. The atomic fluorescence based Series 2600-IVS Mercury Analysis System has a number of unique features that increase its performance and flexibility.

## Easy To Set Up

The Series 2600-IVS assembles for operation in only minutes. A Quick Start Guide will have you up and running in no time. Free factory training and unlimited telephone/email support is available, in the event you require assistance.

## Simple To Maintain

Reliability is of prime importance whether you're doing analysis at a remote, inhospitable location or in an ultra clean laboratory. Downtime and service calls are simply not an option, so Tekran products are designed to be easily serviceable by the analyst.

## Superior Atomic Fluorescence Detector

The AF detector in the 2600-IVS provides extraordinary sensitivity, stability, and selectivity by having a number of unique features. An optical feedback arrangement and temperature control ensures constant lamp intensity over the course of the run and from day to day. The AF detector has an argon optical path purge and a high sensitivity photomultiplier, rather than a cheaper photodiode UV sensor.

## Unique Separation Technology

The Tekran 2600-IVS features unique in-vial purge technology that removes mercury directly from the sample container. By eliminating liquid transport, the integrity of the analytical train is greatly improved.

## Supports Multiple Methods

Tekran® Series 2600-IVS allows easy migration from a starter system to a fully automated, high throughput configuration. It has the capability to be flexible and quickly modified to run EPA method 1631, 245.7, IO-5 for air, and ISO-6978 and ASTM D5954-98 for natural gas.



## Fast & Accurate Software Takes Performance to a New Level



Tekran® has developed the new Tekran® Mercury Data System (Tek-MDS) software to be faster, more reliable and offer a wide range of expanded capabilities. Tek-MDS-2 has pre-loaded standard methods and the capability to easily construct custom methods.

### Advanced ETF Editor

The new ETF editor makes it easy for advanced users to alter the timing of the series of events used to analyze each sample. The new time line display shows the start time, duration, and end time of all analytical events within a sample sequence.

### Automated Calibration Control

Tek-MSD-2 handles all standard calibration methods, including calibration factors (unweighted regressions) automatically.

### Tek-MDS-2 Software Features:

- Easy To Use Templates
- Real Time Peak Display / Improved Charting
- Lamp Hardware Wizard
- Auto-Flush Clean Criteria
- Add/Delete/Insert Samples at Any Time
- Real-Time Analysis of Standards & QC Samples
- Time Saving Autosampler Location Auto-Fill
- Multi-Level Undo & Redo
- Worksheet Save History Backup
- Data Storage on Network Drives
- One-Click Worksheet Data Copy into Excel

## Want to know more about the best mercury analysis device in its field?

The included CD has complete product information for the following:

- *Series 2600 Individual Components*
- *Standard Method Configurations*
- *Tek-MDS-2 Software*
- *Application notes, photos and more*

### Free Lifetime Technical & Application Support

Tekran® system owners enjoy free lifetime technical and application support by a team of analytical chemists with a combined 45+ years of specializing exclusively in mercury analysis.

## Typical Applications:

### Analysis by Dual-Stage Gold Pre-concentration

- Automated US EPA Method 1631 & US EPA Method 245.7
  - Aqueous samples
  - Biota and sediment samples
  - Petroleum & industry samples
  - Flue gas sorbent traps

### Analysis of Air and Natural Gas Samples

- US EPA Method IO-5
  - Ambient and indoor air samples
  - Fence line monitoring samples
- ASTM Method D6350-14 & ISO 6978-2
  - Natural gas & landfill gas samples

Model 2600 In-Vial Sparging Flow Diagram (Shown During Sample Loading)

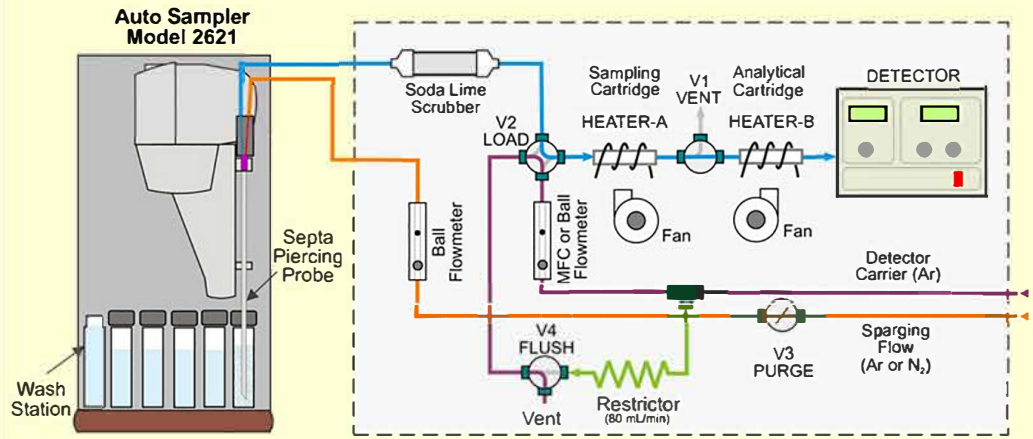

## Key Specifications:

**Detector Type**

**Atomic Fluorescence**

**Sensitivity**

**< 0.1 picogram**

**Method Detection Limit**

**< 0.02 ng/Liter\***

**2600 Footprint**

**9" X 17" (23 x 43 cm)**

**2621 Autosampler Footprint**

**11" X 19" (28 X 48 cm)**

**Power Requirements**

**100/120V or 220 /240V 50/60Hz**

**375 VA max. (full system)**

\*Dual stage pre-concentration. Ultra-clean, controlled reagent blanks required. Sample aliquot: 30 mL



For North American Sales & Service, please contact us at:

**Tekran® Instruments Corporation**

330 Nantucket Boulevard • Toronto, ON M1P 2P4 • Canada  
416-449-3084 • 1-888-5-TEKRAN (1-888-583-5726)

[lab-air-info@tekran.com](mailto:lab-air-info@tekran.com) • [www.tekran.com](http://www.tekran.com)

Authorised Representative:



[www.thomsongroup.com.au](http://www.thomsongroup.com.au)