

GasEye Probe H2O - *IN-SITU* WATER VAPOR ANALYZER



GasEye H2O is a high performance *in-situ* water vapor analyzer. Suitable for safety applications and process control. 24/7 continuous operation. No sample preparation. No zero drift. No field calibration. Low cost of ownership.

Features

- H2O ranges: **0 – 1000 ppmv / 0 – 100%vol**
- Process temperatures **0-500°C**
- Process pressures **0.7-2.0 barA**
- **Real time sensing** – response time below 0.1 second
- **High sensitivity** – detection limit below 10 ppm per meter
- **High selectivity** – automatic compensation for interference effect from other constituents in the gas sample
- ***In-situ* monitoring** – direct in the process, no sample preparation
- **Maintenance free** – equipped with a self-calibrating feature, no field calibration necessary
- **Robustness** – IP66 enclosure, suitable for outdoor and indoor installations and harsh environments
- **Insensitive to dust and smoke in the measured process** – up to 50 g/m³

Example Applications

- **Gas quality measurement**
- **Safety monitoring**
- **Process control**

Example Industries

- Petrochemical industry
- Power industry
- Steel industry
- Chemical industry

Application type: H2O PR 15.01.01-AAA

Analytical performance

H2O measurement range: 0-30 vol%

LoD: 0.1 vol% *m @STP and 3 sec response time

Precision: LOD or 1% of the measured value, whichever is larger @STP and 3 sec response time

Accuracy: LOD or 2% of the measured value, whichever is larger @STP and 3 sec response time

Process dust load: up to 50 g/Nm³ depending on the process

Calibration: Certified span gas

Zero drift and span drift: negligible

Electric characteristics

Power input: 24 VDC nominal (19 - 30 VDC)

Power consumption: < 20 VA

Dynamic performance

Warm-up time: approx. 5 minutes

Minimum response time (T90): 200 milliseconds

Electric inputs and outputs

Inputs:

4 x analog input, (4-20 mA, process temperature and pressure, 2 x AUX) - easy user selection via DIP switch between active/passive mode

1 x RTD

8 x Digital input

Outputs:

4 x analog output, (4-20 mA, H2O concentration, process transmission, 2 x AUX,) active or passive - easy user selection via DIP switch between active/passive mode, selectable signal ranges according to EN 15267-3 or NAMUR NE43

8 x Digital output (MOSFET-based), optionally 4 x dry contact DO

Optional:

PROFINET, Modbus (TCP/IP), Modbus RTU, Profibus DP

Local User Interface:

1. Local User Local User Interface: Interface (LUI) – LCD backlight display located on the transmitter housing lid.

2. Ethernet

- WebServer application – system configuration and data acquisition via webbrowser
- Windows based program – GasEye logger for real time data acquisition

Remote access:

Ethernet port for remote service and diagnostics

Mechanical specification

Degree of protection: In accordance with

IP66 **Process flange:** DN50PN16

Process windows: F.Silica window, Helium leak tested and certified in accordance to EN1779:2002 norm.

Instrument dimensions:

Analyzer: W x H x L: 330 mm x 230 mm x 323 mm

Analyzer with probe: W x H x L: 330 mm x 230 mm x 1600 mm

Active optical path lenght: L: 2x 578 mm

Weight: Analyzer (including probe): 18 kg
 Probe: 6 kg

Materials: Housing: aluminium
 Coating: RAL5010
 Process interface: Stainless steel 316

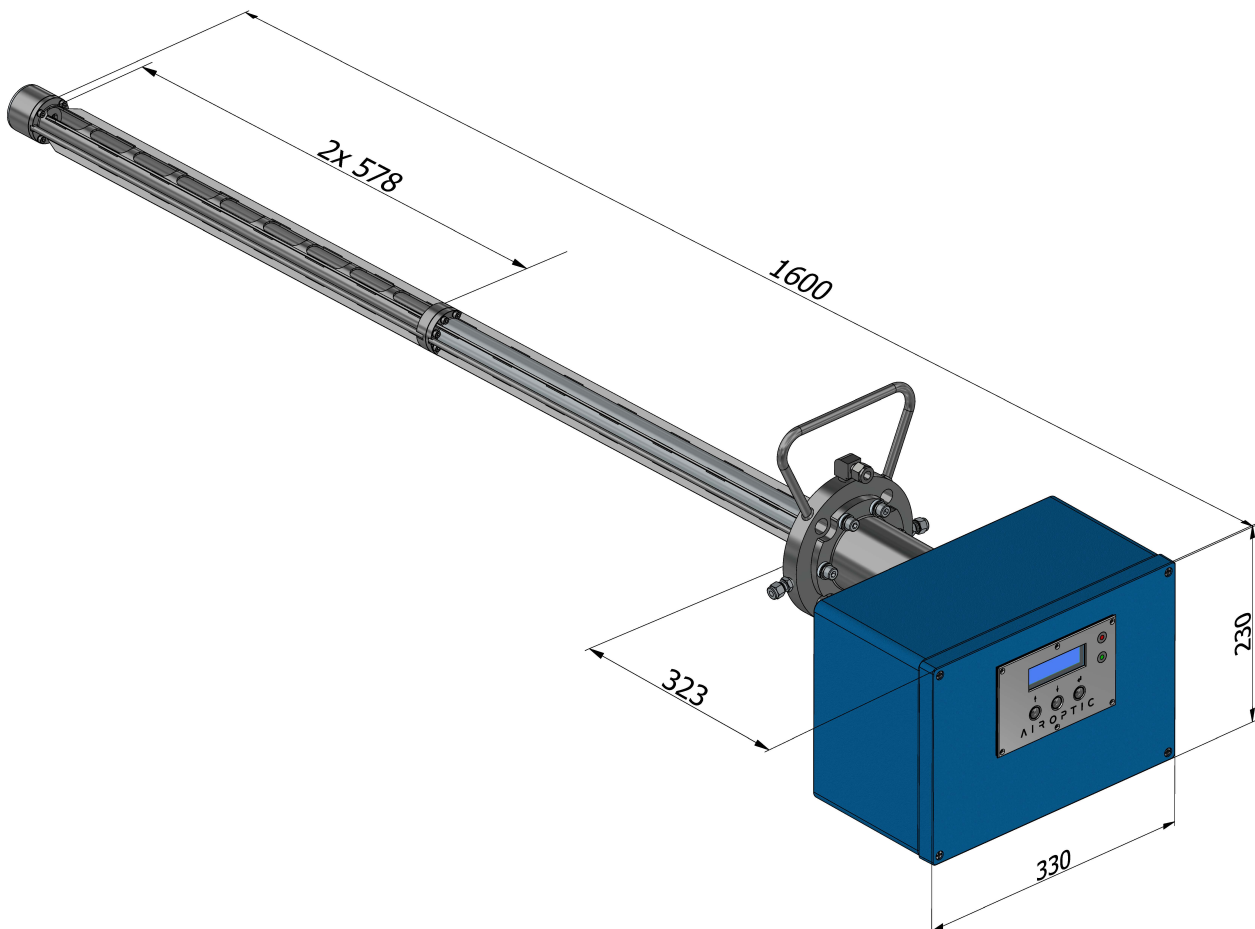

Climatic conditions

Ambient temperature:	-30°C to +60°C
Ambient pressure:	800 - 1200 hPa
Ambient humidity:	RH < 99%, non-condensing

Measurement conditions

Sample gas pressure:	0.7 - 2 barA
Sample gas temperature:	0°C to 500°C

Sensor and Process Purging (Nitrogen)

Purging gas flow rate:	5 – 50 l/min (process dependent)
------------------------	----------------------------------

Safety

Low Voltage Directive (LVD) 2014/35/EU



- PN-EN 61010-1:2011
- Laser radiation: Laser Class I product acc. to PN-EN 60825-1:2014-11

EMC Directive 2014/30/EU

- EN IEC 61326-1:2021

RoHS Directive 2011/65/EU

A I R O P T I C™
REAL TIME GAS ANALYZERS

Airoptic Sp. z o.o.
ul. Rubież 46 B, 61-612 Poznań,
Poland sales@airoptic.pl
www.airoptic.pl
tel. +48 61 6272 128

 **TES** Thomson
Environmental
Systems

www.thomsongroup.com.au