

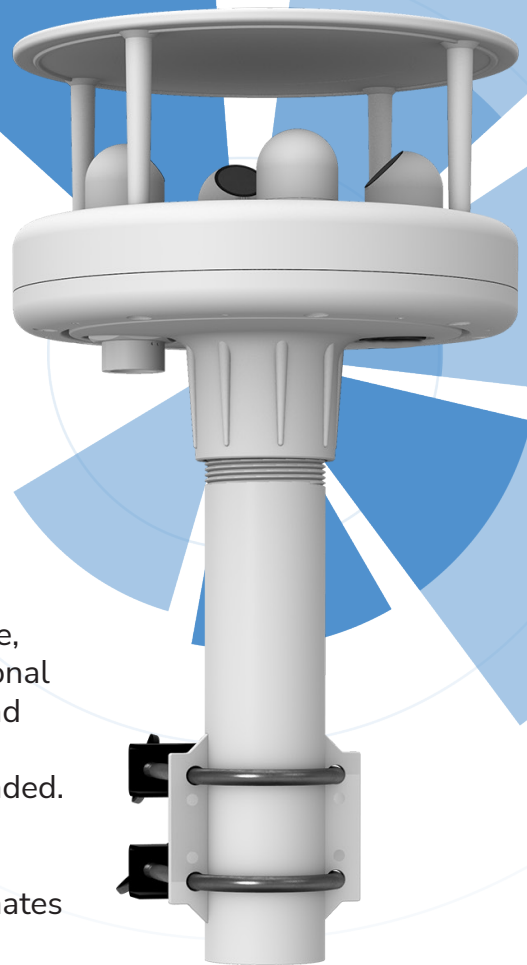

Uplevel your air monitoring with met data

The Clarity Wind Module measures ambient temperature, pressure and relative humidity as well as the 2-dimensional horizontal components of wind speed and direction. Wind and meteorological data provide you better insight into where air pollution is coming from — and where it is headed.

This lightweight and durable sensor is made of molded thermoplastic for high performance in even extreme climates with harsh UV and weather conditions.



SMART VISUALIZER

Enhance your analytics detection with wind roses, integrated directly into your existing Clarity network in the dashboard.

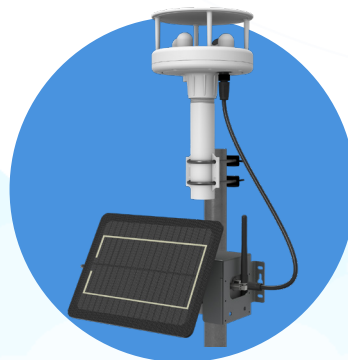

SOLAR POWERED

The Wind Module is powered by the native solar panel of its companion Node-S device, so you don't have to worry about a local power source.

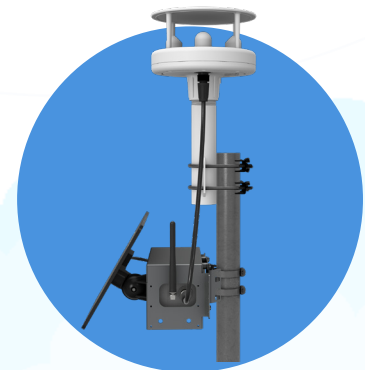

SEAMLESS INSTALL

A plug-and-play solution for better source attribution and improved air quality modeling, integrating seamlessly into existing Clarity Node-S networks



Wind Module Technical Specifications

AIR QUALITY MEASUREMENTS

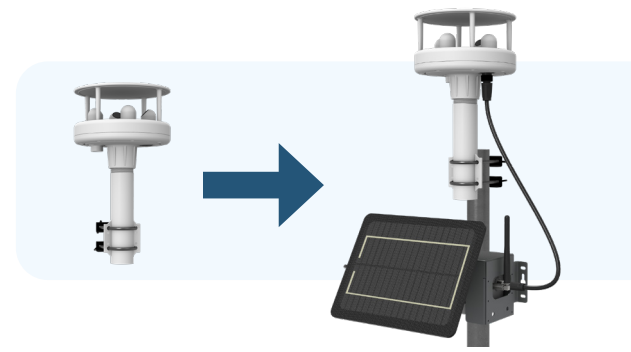

PARAMETER	TECHNOLOGY	RANGE	PERFORMANCE
Wind Speed	Solid-state 2-axis ultrasonic wind sensor	Range: 0 to 60.00 m/s Resolution: 0.01 m/s	Accuracy: ± 2% (at 12m/s)
Wind Direction	Solid-state 2-axis ultrasonic wind sensor	Range: 0 to 359.9° Resolution: 0.1°	Accuracy: ± 3° (at 12m/s)
Atmospheric Pressure	-	300 to 1100 hPa Resolution: 0.02 hPa	Relative Accuracy: ± 0.12 hPa
Ambient Temperature	-	Range: - 20° C to 75° C Resolution: 0.1° C	Accuracy: ± 0.5° C
Ambient Relative Humidity	-	10% to 99.9% RH Resolution: 0.1% RH	Accuracy: ± 2% RH (at 25° C)

DATA FLOW

Measurement Frequency (Adjustable)	- Default: Once every 15 minutes - Sampling synchronized with Node-S to occur simultaneously with air pollutant measurements; see Node-S specifications for details
Data Retrieval from Cloud	- Clarity Dashboard (Web App) - RESTful APIs (Programmatic Access)
Device to Cloud Communication	Connectivity provided by Clarity Node-S (SIM card and service included)

POWER¹

Solar-Powered via Clarity Node-S	Wind Module self-powered via solar panel of companion Node-S device ¹
----------------------------------	--

MOUNTING & DEPLOYMENT

Connect to Node-S	Plug module into Clarity Node; Node will reset and automatically recognize the module
Sensor Siting	- Install sensor in an open area with unobstructed air flow - Align to true north
Mounting	Use the manufacturer-provided mounting bracket to affix to a pole or another secure foundation

OPERATING CONDITIONS

Weatherproof Rating	IP65
UV Exposure	UV-stabilised ABS plastic
Absolute temperature	-40° to 80° C
Operating temperature	See Node-S specifications
Operating humidity	See Node-S specifications

DIMENSIONS

Total (Assembled)	180 mm (Diameter) x 303 mm (H)
Sensor	180 mm (Diameter) x 146 mm (H)
Mount Shaft	40mm (Diameter) x 158 mm (H)
Total Weight	< .5 kg / 1.10 lb



¹ The Node-S can support Wind Module power requirements with a natively-integrated solar panel at default sampling rate.