



SP2000-H

## Gas Sample Probe Series SP®

Versions SP2000, SP2000-H, SP2300-H, SP2400-H

### Special Features

- **Optimum operational reliability**
- **Universal applicability**
- **Adaptation to nearly all process conditions due to its compact and modular design**
- **Easy installation and maintenance**
- **Low dead volume**

### Application

The M&C sample probe versions SP2000, SP2000-H, SP2300-H and SP2400-H are used for continuous gas sampling from dust-loaded, high-temperature and/or humid processes.

### Description

The sample probes are designed for easy installation, reliable operation and trouble-free maintenance. They are versatile in application and depending on the task to be performed, various sample tubes or pre-filters (see data sheets for sample tubes with G 3/4" connection thread and pre-filters with G 3/4" connection, with flange connection and with tube connection) that are not included in the scope of delivery, can be simply screwed into the probe (G 3/4" thread).

The depth filter element (ceramic is standard, optionally glass-fiber or spun-glass filling) with a large surface area is located in a housing with low dead volume outside the process.

The probes are designed in such a way that no tools are required when changing the filter element, the sample line does not have to be dismantled and contamination of the clean gas path is excluded.

The sample tube can be cleaned and purged back from outside the process. The special design of the heating element of the SP2000-H, SP2300-H, SP2400-H (with protective cover) permits controlled heating of the complete filter housing, including the mounting flange up to 180 °C [356 °F] (version /H320 up to 320 °C [608 °F]). This ensures reliable operation outside the process by preventing the temperature from falling below the dew point.

In the standard version, temperature control is carried out by an integrated capillary sensor thermostat with high-temperature limiter

and alarm function for low temperature in a compact design. Test gas injection and reference sampling are also possible at the probe.

Depending on the gas composition, it is possible that the standard material of the probe body (stainless steel 316L) will not be sufficiently corrosion-resistant. In this case, probe SP2300-H made of PTFE or SP2400-H made of Titanium should be used.

Gas Sample Probe Version	SP2000	SP2000-H	SP2300-H	SP2400-H
Part No.	20S1000	20S2000	20S3000	20S3500
Protective cover	No	Yes	Yes	Yes
Degree of protection	IP54 EN 60529			
Filter housing material	Stainless steel 316Ti/316L*		PTFE	Titanium
Sealing materials	FKM* /7aT** = PTFE /H320** = graphite			
Probe flange sealing material	Novapress®			
Sample tube/pre-filter	Optional			
Sample pressure max.	0.4 to 6 bar* abs., /7aT** = 2 bar abs., /HP** = 25 bar abs.		0.4 to 2 bar abs.	0.4 to 6 bar abs.
Ambient temperature	20 to 180 °C [68 to 356 °F]		-20 to +60 °C*** [-4 to 140 °F***] /PT100, /Fe-CuNi, /Ni-CrNi** = -20 to +80 °C [-4 to 176 °F]	
Filter chamber volume	120 cm <sup>3</sup>			
Filter element, porosity	S-2K150 = ceramic*, 2 µm /F-0,1GF150 = glass fiber**, 0.1 µm, /FW = spun glass**			
Thermostat, temperature adjustment	0 to 180 °C* [32 to 356 °F*] /H320** = 0 to 320 °C [32 to 608 °F] /PT100** /Fe-CuNi** /Ni-CrNi**			
Ready for operation	After 40 min /H320** = after 60 min			
Low-temperature alarm contact*	Contact rating: 250 V, 3 A~, 0.25 A= Alarm point: ΔT 30 °C [86 °F]			
Sample gas outlet connection	1 x 1/4" NPT i* tube connectors ø 6, 8 or 10 mm** /H320** = 6 mm			
Blowback/test gas connection	1/4" NPT i* /R**, /H320** = tube ø 6 mm			
Power supply	230 V, 50/60 Hz, 800 W /115 V** = 115 V, 60 Hz, 800 W (fuse protection 10 A)			
Electrical connections	Terminals max. 4 mm <sup>2</sup> , 2 x M20 x 1.5 cable glands			
Electrical equipment standard	EN 61010, EN 60519-1			
Mounting flange	DN 65 PN 6-B	> DN or ANSI possible** /HP** = DN 50 PN 25		
Mounting flange material	SS 316Ti		PTFE	Titanium
Weight	7 kg* [≈ 15.4 lbs*]	15.4 kg* [≈ 34 lbs*]	15.4 kg* [≈ 34 lbs*]	14.5 kg* [≈ 32 lbs*]

\* Standard

\*\* Options (/H320 not for SP2300-H, /7aT\*\* not for SP2300-H and SP2400-H)

\*\*\* For higher ambient temperatures, use option PT100 (Part No. 20S9025) or thermocouple Fe-CuNi and Ni-CrNi, respectively (Part No. 20S9027 or 20S9028) instead of the thermostat controller. Then, an additional electronic temperature controller (see data sheet "Microprocessor-Controlled Temperature Controller Type 70304") is necessary.

Novapress® is a registered trademark used for elastomer-bonded gasket materials produced by Frenzelit GmbH, Germany.

## Differential pressure and T<sub>90</sub> Time

ΔP and T <sub>90</sub> at a flow rate of:	100	200	500	1000	1500	3000 (only /HF)	NI/h
ΔP with new filter element S-2K150/GF150	0.007	0.011	0.02	0.058	0.135	0.240/0.225	bar
T <sub>90</sub> time for SP2000-H without tube	6	3.5	1	< 0.5	< 0.5	< 0.5	s

Please note: NI/h and NI/min refer to the German standard DIN 1343 and are based on these standard conditions: 0 °C [32 °F], 1013 mbar.

## Dimensions

### SP2000-H Basic Version with Options (Examples)

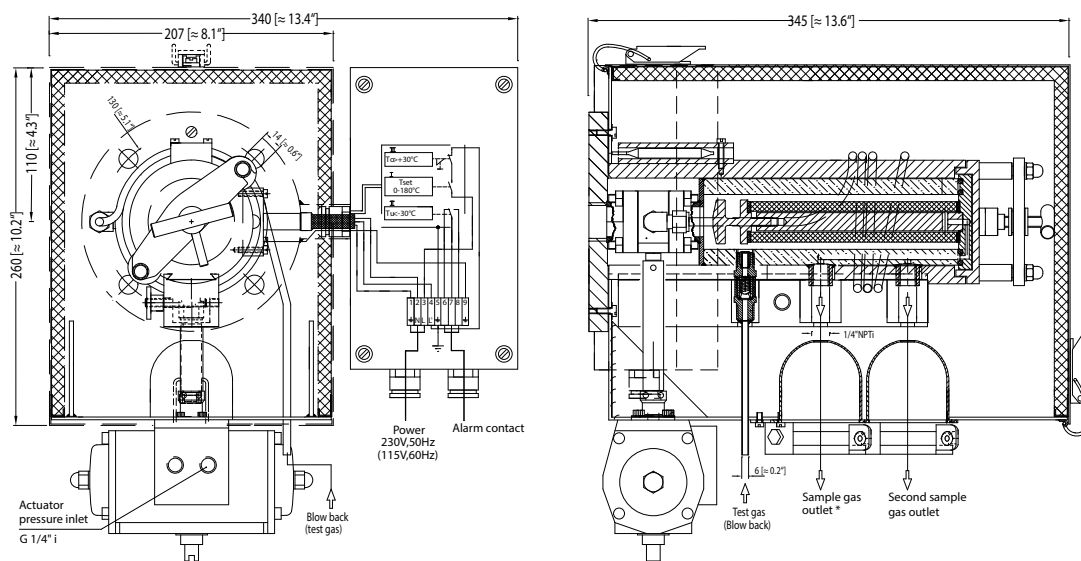

Dimensions in mm [inch]

Basic Versions	Version	Part No.
Basic version, non-heated, without weather protection shield, material: SS 316Ti	SP2000	20S1000
Basic version, heated from 0 to 180 °C [32 to 356 °F], with weather protection shield, material: SS 316Ti	SP2000-H	20S2000
Basic version, heated from 0 to 180 °C [32 to 356 °F], with weather protection shield, material: PTFE	SP2300-H	20S3000(a)
Basic version, heated from 0 to 180 °C [32 to 356 F], with weather protection shield, material: titanium	SP2400-H	20S3500
Options integrated in the gas sample probe (extract)		
Power supply 115 V/60 Hz	/115V	20S9030
Top of filter case with PTFE rings and seals of PTFE	/7aT	20S9010
Second outlet for sample gas 1/4" NPT i	/2x	20S9015
Back-purging/calibration gas valve, opening pressure 0.7 bar, tube 6 mm, blowback and test gas feeding via filter chamber	/R	20S9045
Back-purging/calibration gas valve for SP2400-H, opening pressure 0.7 bar, 1/4" NPT i, blowback and test gas feeding via filter chamber	/R-Ti	20S9048
Fiber glass filter element 0,1GF150, filter porosity 0.1 µm, sealing PTFE	/GF150	20S9020
Special filter housing lid and screw-on receptacle incl. spun-glass filling, sealing FPM, Novapress®	/FW	20S9047
Special filter housing lid and screw-on receptacle incl. spun-glass filling for 320 °C [608 °F], sealing graphite	/FW 320	20S9046
Electrical heating of the external filter from 0 to 320 °C [32 to 608 °F]	/H320	20S9021
Version for max. 25 bar operating pressure, mounting flange DN 50 PN 25	/HP	20S9017
Gas pre-heater GVW1, material: SS 304	/GVW1	20S9058
Connection of the gas pre-heater to valve "R" and to gas inlet	/GVW	20S9062
PT100 sensor instead of the thermostat, without temperature controller	/PT100	20S9025
Thermocouple FE-CuNi ( type J) instead of thermostat, without temperature controller	/Fe-CuNi	20S9027
Thermocouple Ni-CrNi (type K) instead of thermostat, without temperature controller	/Ni-CrNi	20S9028
Second PT100 sensor	/2-PT100	20S9026
Version with electrical safety separation according to VDE106T101 in connection with thermostat	/ST	20S9031
Steam heating, without controller and valves	/D	20S9033
Adapter flange size DN..PN 6 or ANSI..150 lbs	/DN	20S9004
Mounting fitting R2" a or 2"-NPT a instead of the mounting flange	/SO1	20S9005
Integrated 2-way ball valve with lock function in the inlet	/VA	20S9050
Integrated 3-way ball valve with T-function in the inlet	/3VA	20S9325
Integrated 2-way ball valve with lock function in the inlet, up to 320 °C [608 °F]	/VA320	20S9053
Integrated 3-way ball valve with T-function in the inlet, up to 320 °C [608 °F]	/3VA320	20S9330
Pneumatic drive for ball valves VA and 3VA, 2 operating states	/MS1	20S9055
Pneumatic drive for valves VA 320 °C [608 °F] and 3VA 320 °C [608 °F], 2 operating states	/MS3	20S9056
Electrical actuating drive for ball valves VA and 3VA, 2 operating states, 230 V/50 Hz	/EA230	20S9342
Electrical actuating drive for ball valves VA and 3VA, 2 operating states, 115 V/60 Hz	/EA115	20S9342a
Electrical actuating drive for ball valves VA and 3VA, 2 operating states, 24 V DC	/EA24	20S9342d
Filter housing lid for high flow rate with filter element 0,1GF	/HF	20S9016

## Basic Version

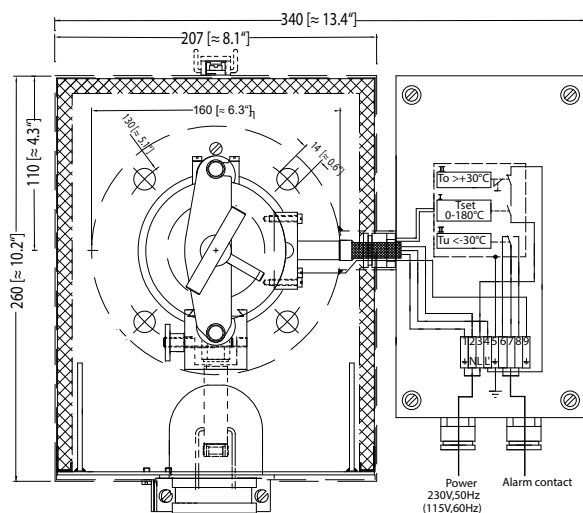

Dimensions in mm [inches]

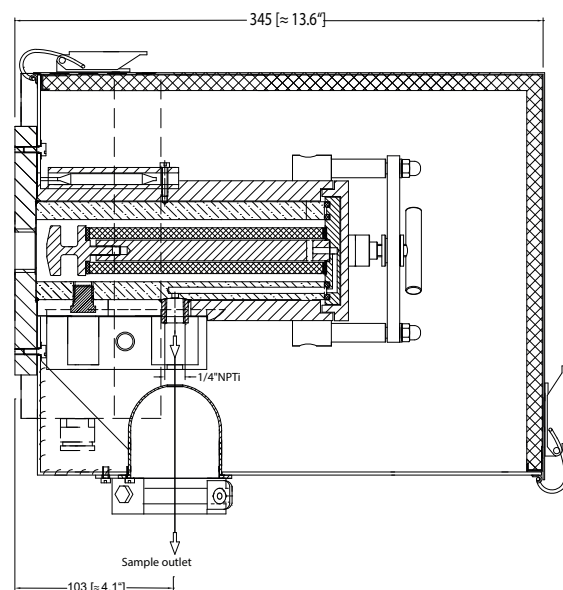

## Options for Basic Versions



Short term	SP2000	SP2000-H	SP2300-H	SP2400-H
/115V	–	X	X	X
/7aT	X	X	–	–
/2x	X	X	X	X
/R	X	X	X	X
/R-Ti	X	X	X	X
/GF150	X	X	X	X
/FW	X	X	–	X
/FW 320	–	X	–	X
/H320	–	X	–	X
/HP	X	X	–	–
/GWW1	–	X	X	X
/GWW	–	X	X	X
/PT100	–	X	X	X
/FeCuNi	–	X	X	X
/Ni-CrNi	–	X	X	X
/2-PT100	–	X	X	X
/ST	–	X	X	X
/D	–	X	X	X
/DN	X	X	–	–
/SO1	X	X	–	X
/VA	X	X	–	–
/3VA	X	X	–	–
/VA320	–	X	–	–
/3VA320	–	X	–	–
/MS1	X	X	–	–
/MS3	X	X	–	–
/EA230	X	X	–	–
/EA115	X	X	–	–
/EA24	X	X	–	–
/HF	X	X	–	–

– not possible

X possible

The above table only indicates the possible options for the different probe types. It does not provide information regarding the possible combinations of these options with each other in a probe model. In case you are looking for several options to be combined, please ask our sales team for technical advice.

Gas sample probe SP2000-H / Filter Elements

2.20

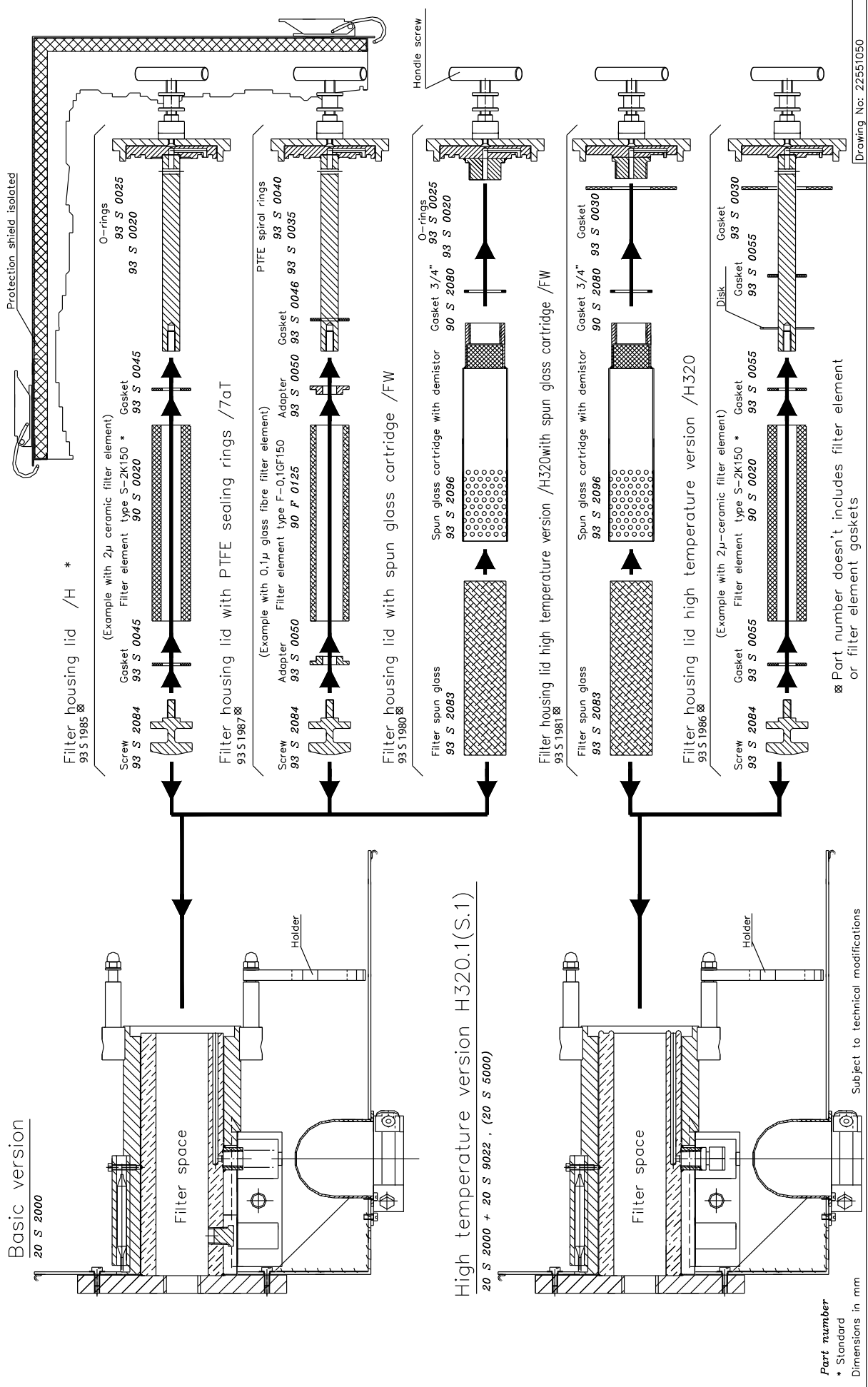

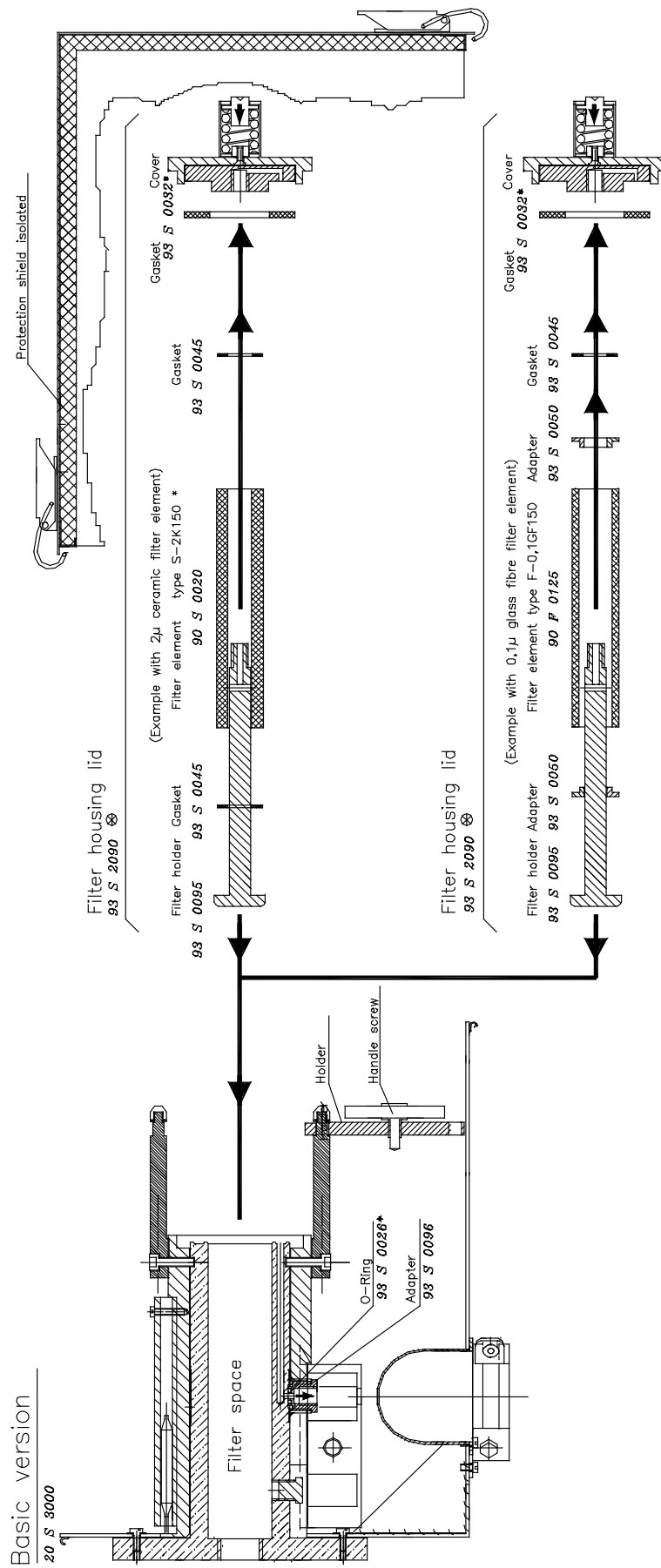

Max. operating over pressure: 1 bar

\* Part number doesn't include filter element or filter element gaskets

Part number  
\* Standard  
Dimensions in mm Subject to technical modifications

Drawing No. 22551065

2.24

Gas sample probe SP2000-H/D steam heated

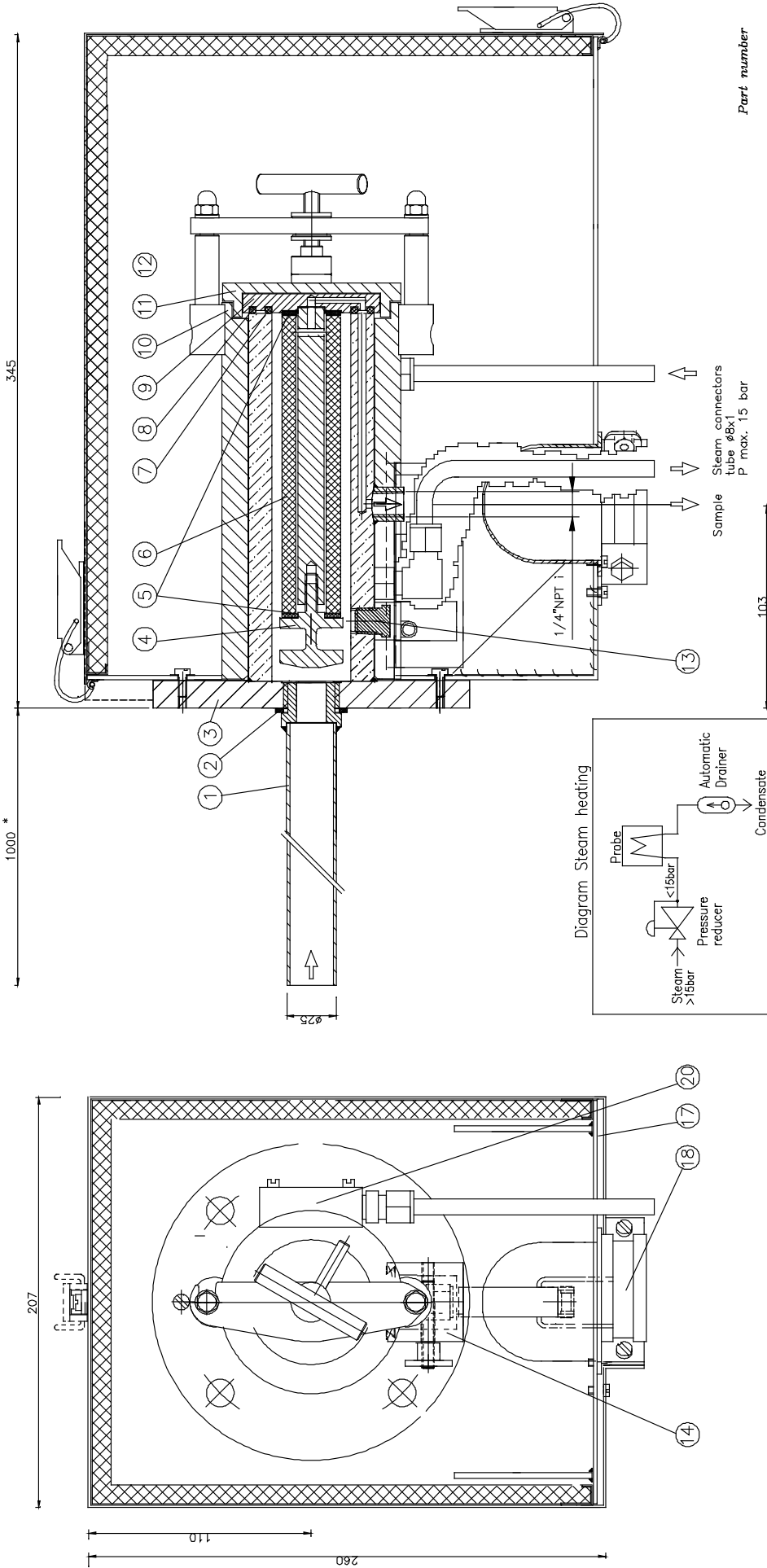

Dimensions in mm		Subject to technical modifications	
Item	Description	Type	Material
1	Sample tube with thread G3/4"		
2	Gasket 3/4"		
3	Flange	DN65/PN6	SS316
4	Filter screw M6		SS316
5	Gasket 30		SS304
6	Filter element 2 micron	S-2K-150	Ceramic
7	O-Ring 39		93 S 0020
8	O-Ring 55		93 S 0025
9	Cover plate With filter holder	V	SS316
10	Al-heater body		Anodized Al
11	Al-cover plate		Anodized Al
12	Clamp		SS304
13	Plug		SS316
14	Thermal conductivity jaws		Anodized Al
15			
16			
17	Weather protection shield		98 S 0075 painted Steel
18	Clamp 1 1/4"		98 S 0065 Steel
19			
20	Steam heater body with connectors	SP2000 /H/D	20 S 9033 Anodized Al
21			

Drawing No: 22551141

Gasentnahmesonde/Sample probe SP2000-H.../...VA...		2.25
Version mit 2-Wege-Kugelhahn zum Absperrn für Prüfgasaufgabe oder Service Anwendungsempfehlung: Filterwechsel, Reinigung usw. bei über-/Unterdruck, giftigen, korrosiven Gasen. Type with 2-way ball valve to shut off for calibration or maintenance. Recommended application: filter changing, cleaning etc. at over- or underpressure conditions, poisonous or corrosive samples.		
Funktion / function	Version / type	2-Wege-Kugelhahn VA/2-way ball valve VA
2-Wege-Kugelhahn VA zum Absperrn der Gasentnahmesonde vom Prozeß.	Gasentnahmesonde / Sample probe SP2000-H/VA	
2-way ball valve VA for shut off the sample probe from process.		
2-Wege-Kugelhahn VA zum Absperrn der Gasentnahmesonde vom Prozeß Prüfgasaufgabe über Rückschlagventil R .	Gasentnahmesonde / Sample probe SP2000-H/R/VA	
2-way ball valve VA for shut off the sample probe from process. Calibration gas trough checkvalve R .		
2-Wege-Kugelhahn VA mit pneum. Antrieb MS zum aut. Absperrn der Gasentnahmesonde vom Prozeß.	Gasentnahmesonde / Sample probe SP2000-H/VA/MS-NC (NO)	Magnetventileinheit Solenoid valve unit
2-way ball valve VA with pneum. actuator MS for aut. shut off the sample probe from process.		Steuerluft Control air P= 5,5-8bar
Version 320°C : pneum. Antrieb MS-DA mit 2.Steuermagnetventil (P=>6,5bar)/Type 320°C : pneum. actuator MS-DA with 2. control solenoid valve (P=>6,5bar)		
2-Wege-Kugelhahn VA mit pneum. Antrieb MS zum aut. Absperrn der Gasentnahmesonde vom Prozeß. Prüfgasaufgabe über Rückschlagventil R .	Gasentnahmesonde / Sample probe SP2000-H/R/VA/MS-NC (NO)	Magnetventileinheit Solenoid valve unit Typ 3
2-way ball valve VA with pneum. actuator MS for aut. shut off the sample probe from process. Calibration gas trough checkvalve R .		Steuerluft Control air P= 5,5-8bar  Prüfgas 2 Cal. gas  Prüfgas 1 Cal. gas
Zeichn.-Nr.: /Drawing No: 22551110		

Gasentnahmesonde/Sample probe SP2000-H.../...VA...		2.25
Version mit 3-Wege-Kugelhahn zum Absperren für Rückspülen, Prüfgasaufgabe oder Service Anwendungsempfehlung: Filterwechsel, Reinigung usw. bei Über-/Unterdruck, giftigen, korrosiven Gasen. Type with 3-way ball valve to shut off for backflush, calibration or maintenance. Recommended application: filter changing, cleaning etc. at over- or underpressure conditions, poisonous or corrosive samples.		
Funktion / function	Version / type	3-Wege-Kugelhahn 3VA/3-way ball valve 3VA
<p>3-Wege-Kugelhahn 3VA zum Absperren der Gasentnahmesonde vom Prozeß. Rückspülung und Prüfgasaufgabe über Kugelhahn 3VA.</p> <p>3-way ball valve 3VA to shut off the sample probe from process. Backflush and calibration through 3-way ball valve 3VA.</p>	<p>Gasentnahmesonde / Sample probe SP2000-H/3VA</p> <p>1 = Messen/Measuring 2 = Absperren / Rückspülen Shut off / Backflush 3 = Absperren / Prüfgasaufgabe Shut off / Calibration</p>	
<p>3-Wege-Kugelhahn 3VA mit pneum. Antrieb MS (0-90°) zum autom. (Fernsteuerung) Absperren der Gasentnahmesonde vom Prozeß. Rückspülung (MS-B) oder Prüfgasaufgabe (MS-C) über Kugelhahn 3VA.</p> <p>3-way ball valve 3VA with pneum. actuator MS (0-90°) to shut off the sample probe from process automatically Backflush (MS-B) or calibration (MS-C) through 3-way ball valve 3VA.</p>	<p>Gasentnahmesonde / Sample probe SP2000-H/3VA/MS-C (MS-B)</p> <p>1 = Messen/Measuring 2 = Absperren / Rückspülen Shut off / Backflush 3 = Absperren / Prüfgasaufgabe Shut off / Calibration</p>	<p>Magnetventileinheit Solenoid valve unit Typ 3/2</p> <p>Steuerluft Control air P= 5,5-13,5bar</p> <p>Prüfgas 2 Cal. gas</p> <p>Prüfgas 1 Cal. gas</p> <p>(Rückspülung) Backflush</p>
Version 320°C : pneum. Antrieb MS-DA mit 2.Steuermagnetventil (P=>6,5bar) / Type 320°C : pneum. actuator MS-DA with 2. control solenoid valve (P=>6,5bar)		
<p>3-Wege-Kugelhahn 3VA mit pneum. Antrieb MS (0-90°) zum autom. (Fernsteuerung) Absperren der Gasentnahmesonde vom Prozeß. Rückspülung über Kugelhahn 3VA. Prüfgasaufgabe über Rückschlagventil R .</p> <p>3-way ball valve 3VA with pneum. actuator MS (0-90°) to shut off the sample probe from process automatically. Backflush through 3-way ball valve 3VA. Calibration through check valve R .</p>	<p>Gasentnahmesonde / Sample probe SP2000-H/R/3VA/MS-B</p> <p>1 = Messen/Measuring 2 = Rückspülen / Prüfgasaufgabe Backflush / Calibration</p>	<p>Magnetventileinheit Solenoid valve unit Typ 4</p> <p>Steuerluft Control air P= 5,5-13,5bar</p> <p>Prüfgas 2 Cal. gas</p> <p>Prüfgas 1 Cal. gas</p> <p>Rückspülung Backflush</p>
<p>3-Wege-Kugelhahn 3VA320 mit pneum. Antrieb 2MS-SO (0-90-180°) zum autom. Absperren der Gasentnahmesonde vom Prozeß. Rückspülung und Prüfgasaufgabe über Kugelhahn 3VA.</p> <p>3-way ball valve 3VA320 with pneum. actuator 2MS-SO (0-90-180°) to shut off the sample probe from process automatically. Backflush and calibration through 3-way ball valve 3VA.</p>	<p>Gasentnahmesonde / Sample probe SP2000-H320/3VA320/2MS-SO</p> <p>1 = Messen/Measuring 2 = Absperren / Rückspülen Shut off / Backflush 3 = Absperren / Prüfgasaufgabe Shut off / Calibration</p>	<p>Magnetventileinheit Solenoid valve unit Typ 6</p> <p>Steuerluft Control air P= 6,5-13,5bar</p> <p>Prüfgas 2 Cal. gas</p> <p>Prüfgas 1 Cal. gas</p> <p>Rückspülung Backflush</p>

Zeichn.-Nr.: /Drawing No: 22551110/BI.2

2.26

Solenoid valve unit 2 for gas sample probe SP2000/3VA/MS-B or /MS-C

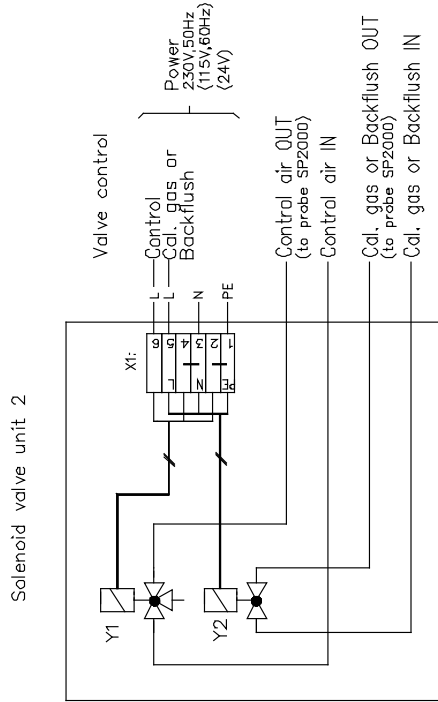
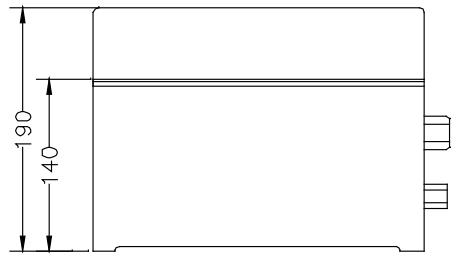
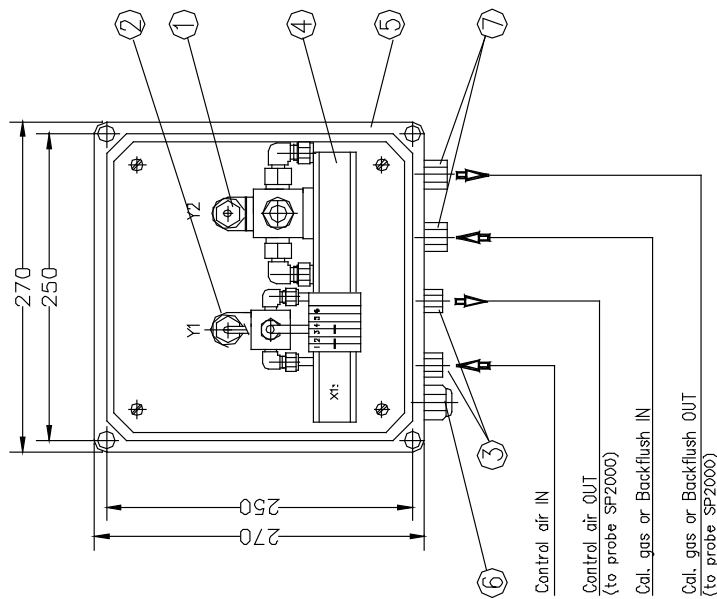

Part number  
2055845

*Standard Dimensions in mm		Subject to technical modifications	
Item	Description	Type	Material
8			
15			
16			
17			
18			
19			
20			
21			

Item	Description	Type	Material
8			
9			
10			
11			
12			
13			
14			

Drawing No: 22551060

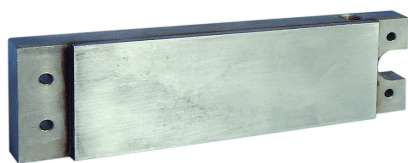

SP2000-H/GVW1

## Gas Pre-Heater Series SP®

Version SP2000-H/GVW1(2)

### Special Features

- Prevents temperature drop below the dew point inside the probe
- Factory assembly
- 2 variants with one or two paths

### Application

The M&C GVW1(2) gas pre-heater is used to pre-heat the backpurging or dilution gas of gas sample probes of the SP2000 series in order to prevent possible cooling down inside the gas sample probe. Subsequent problems related to temperatures drops below the dew point resulting in malfunction and corrosion are thus avoided.

### Description

The M&C gas pre-heaters GVW1(2) consist of heat exchanger plates made of stainless steel and can be directly mounted to the heating system of the sample probe series SP2000-H.

The pre-heater type GVW2 is especially designed for the dilution probes SP2000-H/DIL. With its two gas paths, dilution gas as well as bypass gas can be pre-heated to achieve faster response times.

The optional backpurging connection to the probe of series SP2000-H is ensured via a 6-mm-tube (standard).

## Dimensions

## GVW1

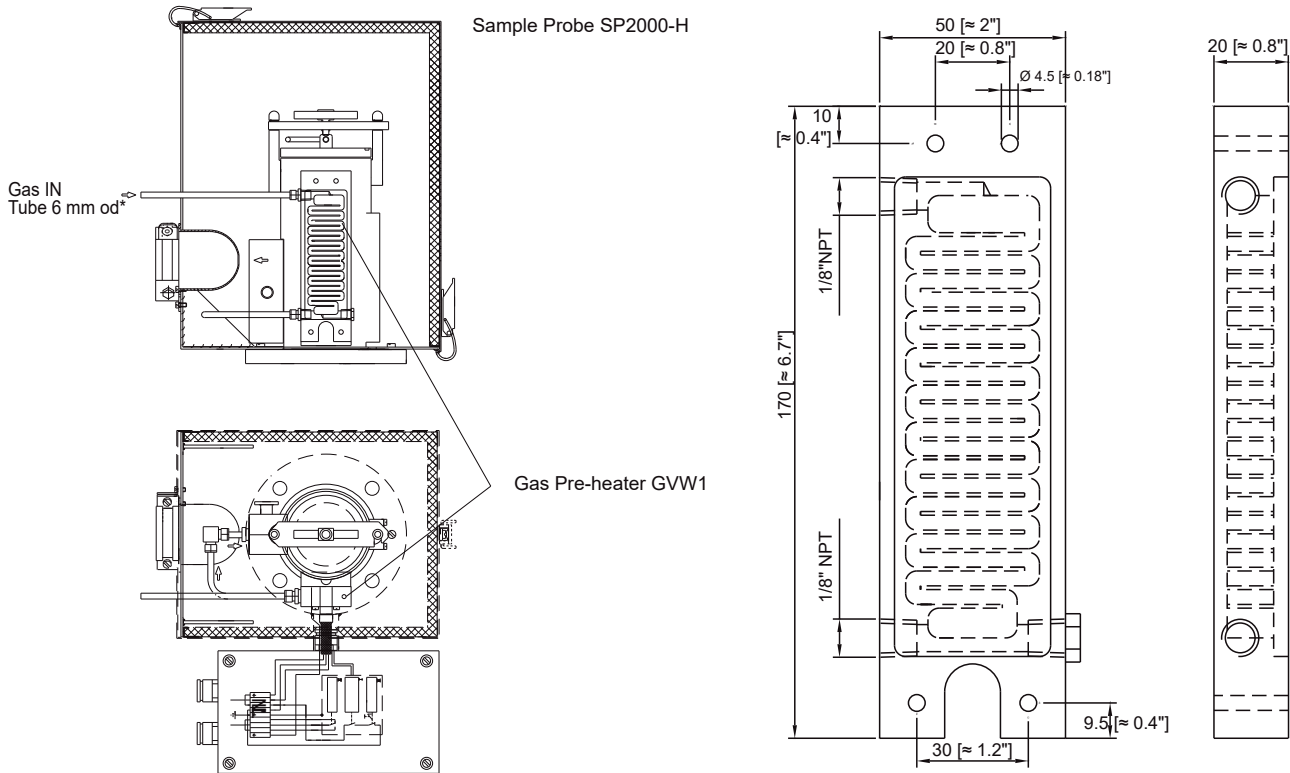

## GVW2

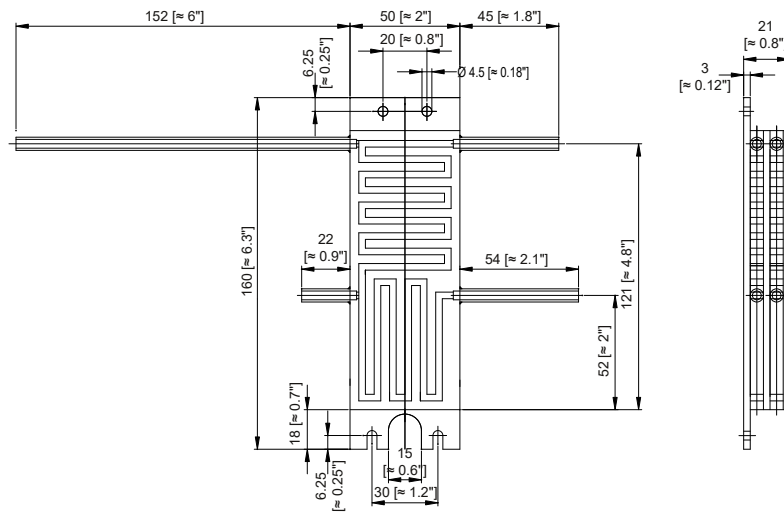

Dimensions in mm [Inches]

## Technical Data

	Version GVW1	Version GVW2
Part No.	20S9058	20S9060
Material	Stainless steel SS 316Ti	
Operating temperature max.	350 °C [662 °F]	
Operating pressure max.	6 bar g	
Flow rate max.	-R, 2 bar inlet pressure: 3.0 m <sup>3</sup> /h, with constant outlet temperature	
(GVW2 1/2 value per gas path)	-R, 6 bar inlet pressure: 8.5 m <sup>3</sup> /h, with outlet temperature drop of 10 °C in 1 min	
Gas connections	GVW1: 1/8" NPT i, GVW2: 6-mm-tube	
Option	SP2000-H/GVW, Part No. 20S9062 connection from the pre-heater GVW1 to the backpurging/calibration gas valve /R and gas inlet via 6-mm-tube made of SS 316Ti .	



[www.thomsongroup.com.au](http://www.thomsongroup.com.au)