



TELEDYNE ANALYTICAL INSTRUMENTS

FLAME IONIZATION ANALYZERS

AND

SERIES 4000

GAS CHROMATOGRAPHS



- 4020 Total Hydrocarbon
- 4030 Total Hydrocarbon heated for emissions
- 4040 Methane / Nonmethane
- 4060 Benzene / Acetaldehyde
- 4080 Total Hydrocarbon in Water

 **TES** Thomson
Environmental
Systems
www.thomsongroup.com.au



Series 4000 Analyzers and Systems

Flame Ionization

Because of its relatively high sensitivity to most organic compounds, the flame ionization detector is a powerful tool for measuring hydrocarbon impurities in other gases. It also provides a linear response over a wide range of analysis.

The figure shows the general construction of an FID. Organic compounds from the sample stream or separation column are injected into the detector housing where they are mixed with Hydrogen and air before entering the detector jet where the mixture is burned.

During this process, organic compounds are broken down into carbon fragments and acquire a positive charge (i.e., become ionized) at the surface of the anode. Carbon fragments are detected by the collector. The signal is then amplified and sent to the data processing system.

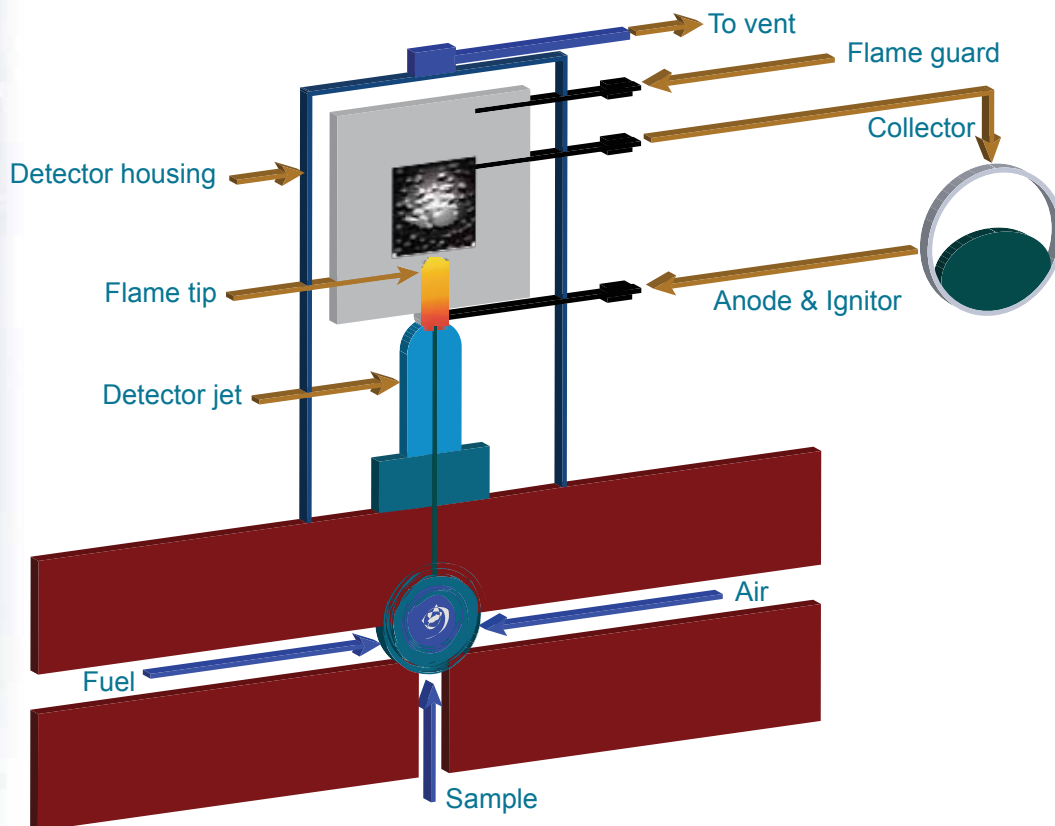

Series 4000 Features

- Easy to use software, user programmable ranges
- GC technology used for complete separation of Methane, Ethlene oxide, Benzene, Styrene, BTX and many other compounds (application dependent)
- Automatic fuel shut off system
- Electronic flame-out guard circuit
- Adjustable alarm and oven settings
- Fast response
- Sample filter with exchangeable stainless steel element
- Built-in sample pump (optional)
- Stainless steel sample system with flexible design to handle either a 100% H₂, H₂ / N₂, or H₂ / He support gas fuel mixture
- Automatic ignition
- X-purged configuration for hazardous area installations available
- Standard auto-calibration programming – ideal for unmanned plant conditions
- Enhanced temperature control of sample compartment for stable, reproducible results
- Easily accessible pressure and flow control devices
- Slide out chassis design for easy access to internal components
- CE marked
- Optional methanizer for CO and CO₂ measurements

Series 4000: Product Configurations



TAI Model 4020 uses a field-proven FID detector to measure THC in various streams. This instrument is ideal for monitoring hydrocarbon contamination in high purity bulk gases.

When coupled with Teledyne's unique separation column, the 4020 is also diverse enough to be applied in hazardous locations for the detection of volatile hydrocarbons in cooling water for process leak detection and environmental compliance.

4020 Total Hydrocarbon Analyzer

Applications

- Monitoring the purity of oxygen, argon, nitrogen and other blanketing gases in the manufacture of microcircuits
- Monitoring hydrocarbon contamination in air liquefaction and other gas production processes
- Gas purity certification
- Detecting trace hydrocarbons in ambient air
- Detecting atmospheric pollutants
- Monitoring for fuel leakage or toxic solvents
- Monitoring hydrocarbons in CO₂ feed streams in the food/beverage industry

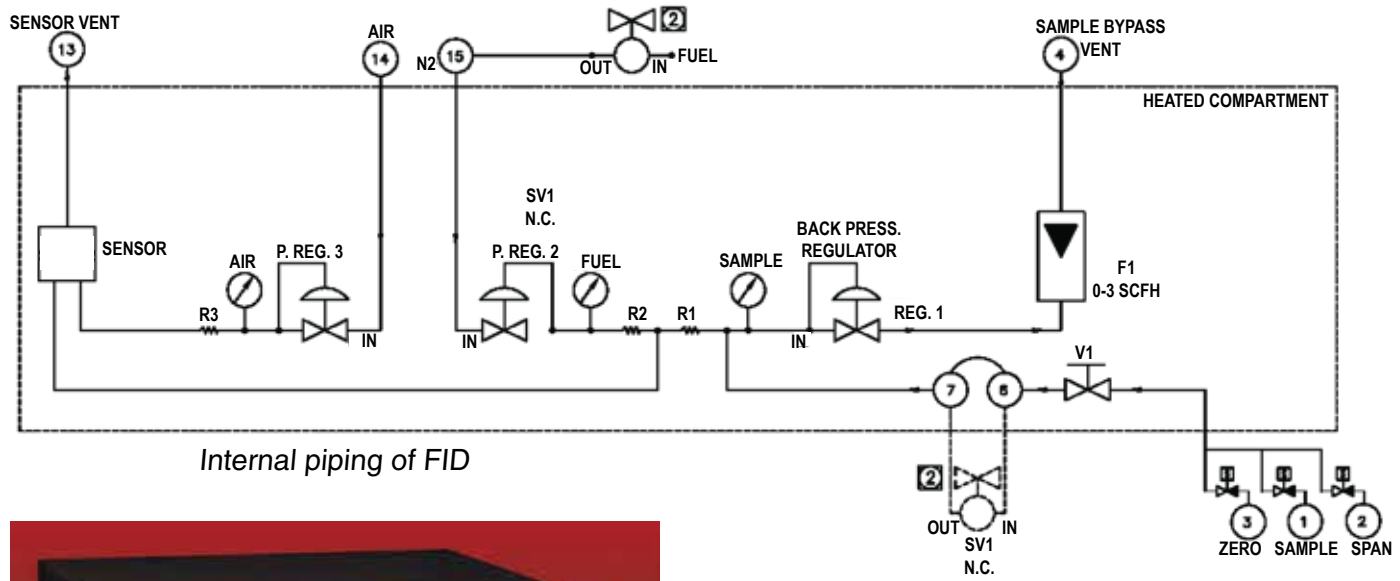

Model 4030 uses TAI's field proven FID detector in a heated chamber. The chamber is heated to a high temperature to meet US EPA requirements for VOC emissions monitoring.

Applications

- Ambient monitoring of THC
- THC measurement of automotive exhaust

4030 Total Hydrocarbon Analyzer heated for emissions

Series 4000: Product Configurations

4040 Methane Non-Methane Analyzer for ambient and process applications

Teledyne's Model 4040 is a microprocessor-based, oven heated methane / non-methane gas analyzer designed for high accuracy, sensitivity and stability. The 4040 is designed to measure varieties of hydrocarbon concentrations from a sampling point.

Applications

- Process monitoring – Monitoring and alarm or control of: process gas streams utilizing organic solvents, crude oil, and other chemicals containing hydrocarbons
- Efficiency monitoring – Monitoring effluent of volatile organic compounds (VOC) reduction equipment for environmental compliance, efficiency control of incinerators (thermal or catalytic), scrubbers, carbon adsorbers, and other abatement equipment, monitoring of catalytic converters, combustion and diesel engine efficiency
- Ambient monitoring – Monitoring and / or control of ovens / dryers, fugitive emissions monitoring, personnel work area monitoring, leak detection of process equipment or solvent storage areas

4060 Benzene / Acetaldehyde Analyzer for ambient, food & beverage, and process applications

Model 4060 is a microprocessor based instrument ideal for the specific monitoring of trace levels of Benzene in gases such as carbon dioxide, air, and nitrogen. Designed as an on-line analyzer in a 19" rack, the Model 4060 comes with three standard ranges, the most sensitive at 100 ppb full-scale. This analyzer can be configured to measure Acetaldehyde or BTX measurements for food and beverage and ambient applications.



Applications

- Monitoring Benzene in CO2 feed streams in the food and beverage industry
- Detecting trace levels of Benzene in ambient air
- Monitoring the purity of nitrogen, oxygen, argon and other blanketing gases
- Monitoring ethylene oxygen in sterile environments

4080 Total Hydrocarbon in Water Analysis System

Teledyne's 4080 is designed to detect hydrocarbons (C1 – C9+) which may not absorb in the UV region

Features

- Temperature Controlled Stripper System effectively strips hydrocarbons from water by cross flowing N2 over the packed stripper column. Includes Drier Assembly to ensure a dry sample gas is delivered to the analyzer.
- Dual-sided, freestanding rack with Stripper Sample System mounted on the backside and Model 402REU NEMA-4 enclosure provided on front



Applications

- Detects Total Hydrocarbons in cooling tower condensate and offshore platforms in produced water

Series 4000: Schematics

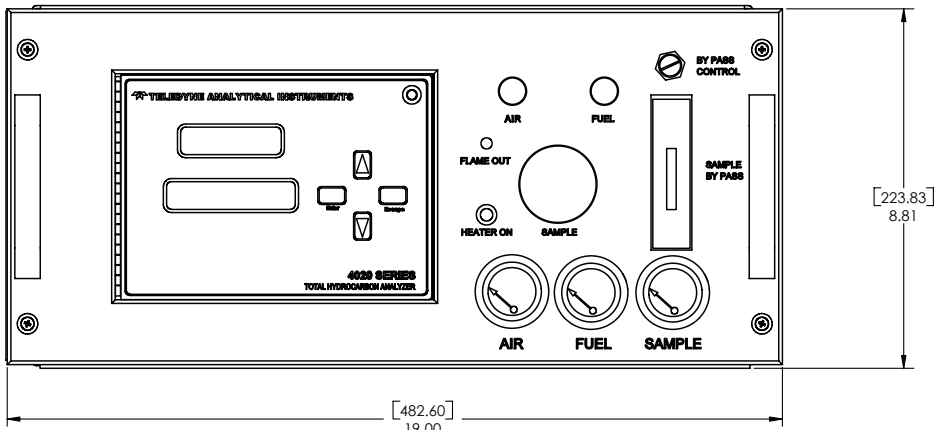

FRONT VIEW

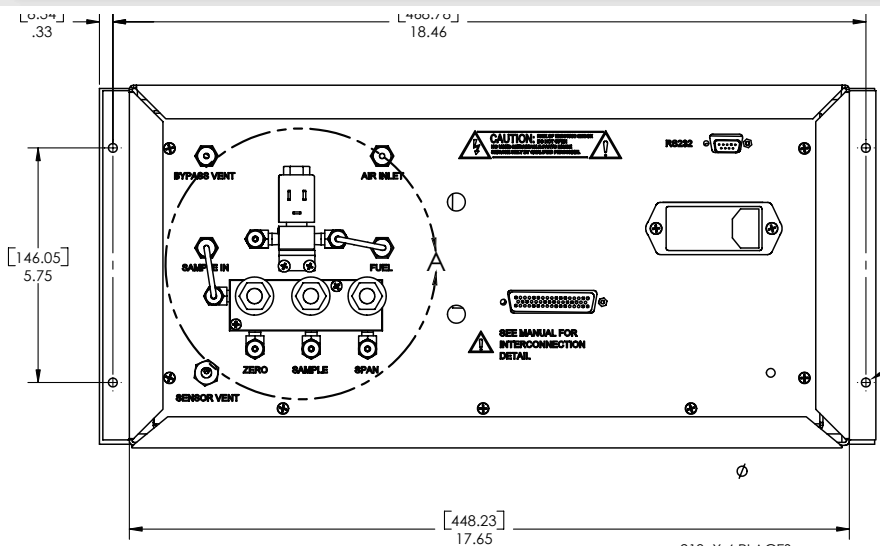

REAR VIEW

**Recommended panel cutout:
17.5" x 8.95" [445 mm x 227 mm]**

SERIES 4000 OVERVIEW

All 4000 series units employ the same basic architecture and electronics. Here are the additional features of each analyzer:

- 4020:** "Total Hydrocarbon Analyzer" -- Uses FID to measure total hydrocarbons in ppm in a sample gas stream.
- 4030:** "Total Hydrocarbon Analyzer" -- Basic 4020 with sample system at a higher temperature for heated applications. Avoids condensation of the sample.
- 4040:** "Methane/Non-Methane" -- Basic 4020, plus temperature-controlled sampling system with GC column to give accurate readings of both Methane hydrocarbons and non-Methane hydrocarbons in a gas stream.
- 4060:** "Benzene Analyzer" -- Same as 4040, but used to measure ppb levels of Benzene instead of Methane/Non-Methane.
- 4080:** "Total Hydrocarbon Stripper" -- Basic 4020 with sample system including stripper to measure total hydrocarbons in an aqueous sample.

* Any other hydrocarbon -- i.e., B2X or Acid Aldehyde -- can be measured with the 4040 or 4060.



Series 4000: Schematics

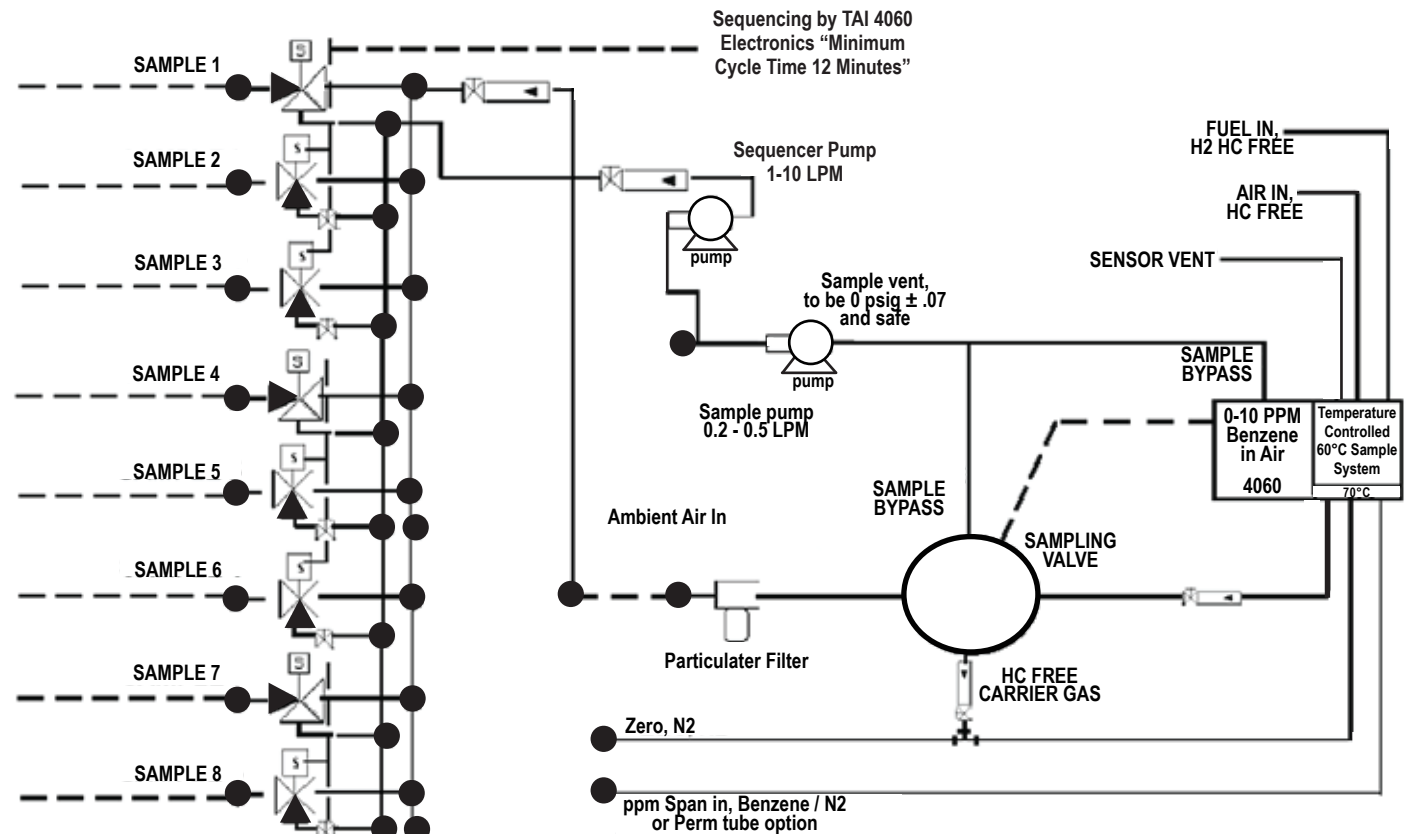

Piping for Benzene in Air Application

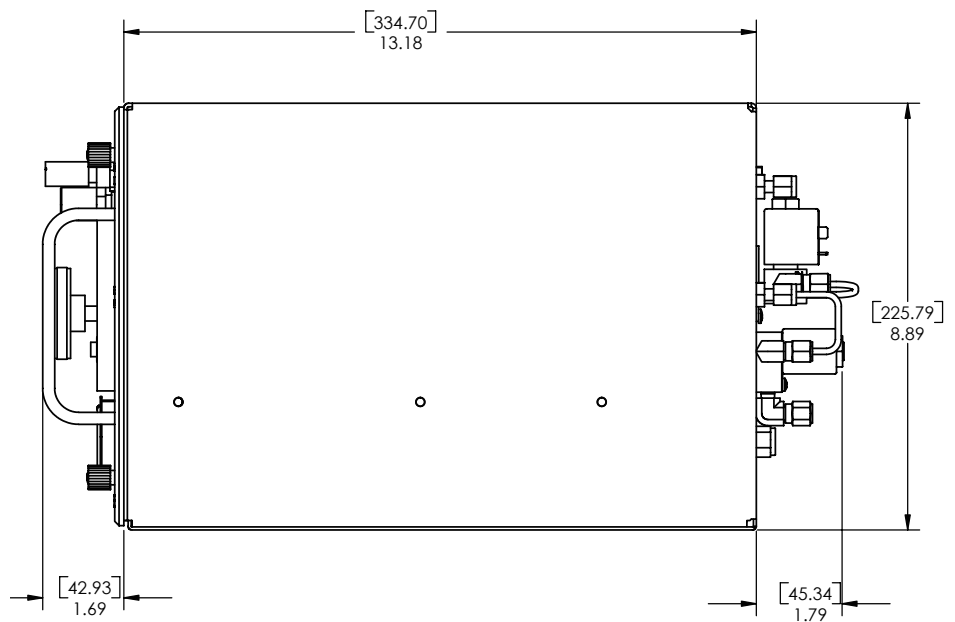

SIDE VIEW

Series 4000 Specifications

	4020	4030	4040	4060	4080
Ranges	0-10, 0-100, 0-1000 ppm HC standard (CH ₄ equivalent, lower optional ranges available)	0-10, 0-100, 0-1000 ppm THC. Other ranges available.	3 Standard ranges; 0-10, 0-100, 0-1000 ppm; Other ranges available.	0-100 ppb, 0-1 ppm, 0-10 ppm benzene. Other ranges available.	0-10, 0-100, 0-1,000 ppm. Other ranges available.
Sensitivity	1% of FS	1% of FS	1% of FS	1% of FS	1% of FS
Resolution	10 ppb on 0-1 ppm range	0.1 ppm	0.1 ppm	1 ppb	0.1 ppm
Accuracy	+ 2% of FS at constant temperature	± 2% of FS at constant temperature	± 2% of FS at constant temperature	± 2% of FS at constant temperature	± 2% of FS at constant temperature
Response time	90% in less than 15 seconds	90% in less than 15 seconds, data updated every 5 minutes	90% in less than 15 seconds, data updated every 10 minutes or less	90% in less than 15 seconds, data updated every 10 minutes or less	90% in less than 15 seconds
Operating temp	40 – 110° F	40 – 110° F	40 – 110° F	40 – 110° F	40 – 110° F
Fuel	Mixtures of 40% hydrogen / 60% nitrogen recommended*	UHP Hydrogen @ 30 psi incoming pressure (standard)	UHP Hydrogen @ 30 psi incoming pressure (standard)	UHP Hydrogen @ 30 psi incoming pressure (standard)	Mixture of 40% hydrogen, 60% nitrogen
Sensor type	Flame ionization with flame guard	Flame ionization with flame guard	Flame ionization with flame guard	Flame ionization with flame guard	Flame ionization with flame guard
Separation method	No separation required	No separation required	G.C. column to separate CH ₄ from other HC	G.C. column to separate C ₆ H ₆ or other hydrocarbons from other aromatics	No separation required
Alarms	“C” Type contact for power failure / flame out; Concentration 2 alarms: Relay “C” contact (fully programmable); 3 A, 250 VAC 50/60 Hz	“C” Type contact for power failure / flame out; Concentration 2 alarms: Relay “C” contact (fully programmable); 3 A, 250 VAC 50/60 Hz	“C” Type contact for power failure / flame out; Concentration 2 alarms: Relay “C” contact (fully programmable); 3 A, 250 VAC 50/60 Hz	“C” Type contact for power failure / flame out; Concentration 2 alarms: Relay “C” contact (fully programmable); 3 A, 250 VAC 50/60 Hz	“C” Type contact for power failure / flame out; Concentration 2 alarms: Relay “C” contact (fully programmable); 3 A, 250 VAC 50/60 Hz
Max load impedance	4-20 mA isolated output 500 ohms	4-20 mA isolated output 500 ohms	4-20 mA isolated output 500 ohms	4-20 mA isolated output 500 ohms	4-20 mA isolated output 500 ohms
System power requirements	115 or 220 VAC, 50/60 Hz	115 or 220 VAC, 50/60 Hz	115 or 220 VAC, 50/60 Hz	115 or 220 VAC, 50/60 Hz	115 or 220 VAC, 50/60 Hz
Max power consumption	90 VA	600 VA	600 VA	600 VA	600 VA
System pressure	19” rack mounted steel enclosure, 19” W x 8.75” H x 15.5” D (48.3 x 22.2 x 39.4 cm)	19” rack mounted steel enclosure, 19” W x 8.75” H x 25.0” D (48.3 x 22.2 x 63.5 cm)	19” rack mounted steel enclosure, 19” W x 8.75” H x 25.0” D (48.3 x 22.2 x 63.5 cm)	19” rack mounted steel enclosure, 19” W x 8.75” H x 25.0” D (48.3 x 22.2 x 63.5 cm)	
Zero & Span noise	Less than 0.5% of full scale	Less than 0.5% of full scale	Less than 0.5% of full scale	Less than 0.5% of full scale	Less than 0.5% of full scale
Zero & Span drift	2% full scale per week	2% full scale per week	2% full scale per week	2% full scale per week	2% full scale per week
Linearity	1% of full scale through all ranges	1% of full scale through all ranges	1% of full scale through all ranges	1% of full scale through all ranges	1% of full scale through all ranges
Repeatability	1% of full scale through all ranges	1% of full scale through all ranges	1% of full scale through all ranges	1% of full scale through all ranges	1% of full scale through all ranges

Series 4000 Specifications

	4020	4030	4040	4060	4080
Sample chamber	NA required	100-120° C per application	50-80° C per application; higher temps available	50-80° C per application; higher temps available	NA required
Flow rate	1 liter / minute (standard)	1 liter / minute (standard)	1 liter / minute (standard)	1 liter / minute (standard)	1 liter / minute (standard)
Safety	Flame-out alarm and fuel shut off. Includes red indicator lamp and activation of system fail alarm relay	Flame-out alarm and fuel shut off. Includes red indicator lamp and activation of system fail alarm relay	Flame-out alarm and fuel shut off. Includes red indicator lamp and activation of system fail alarm relay	Flame-out alarm and fuel shut off. Includes red indicator lamp and activation of system fail alarm relay	Flame-out alarm and fuel shut off. Includes red indicator lamp and activation of system fail alarm relay
Outputs	0-1 VDC and 4-20 mADC, Isolated current output	0-1 VDC and 4-20 mADC, Isolated current output	0-1 VDC and 4-20 mADC, Isolated current output	0-1 VDC and 4-20 mADC, Isolated current output	0-1 VDC and 4-20 mADC, Isolated current output
Ignition	Automatic	Automatic	Automatic	Automatic	Automatic
Warm-up time	Usable in approximately 4 hours; stable in approximately 8 hours	Usable in approximately 4 hours; stable in approximately 8 hours	Usable in approximately 4 hours; stable in approximately 8 hours	Usable in approximately 4 hours; stable in approximately 8 hours	Usable in approximately 4 hours; stable in approximately 8 hours
Display	Bright LED concentration display	Bright LED concentration display	Bright LED concentration display	Bright LED concentration display	Bright LED concentration display
Combustion air	Oil / Water Hydrocarbon free instrument air @ 30 psi incoming pressure	Oil / Water Hydrocarbon free instrument air @ 30 psi incoming pressure	Oil / Water Hydrocarbon free instrument air @ 30 psi incoming pressure	Oil / Water Hydrocarbon free instrument air @ 30 psi incoming pressure	Oil / Water Hydrocarbon free instrument air @ 30 psi incoming pressure
Span calibration gas	Known concentration of operator selected hydrocarbons	Known concentration of operator selected hydrocarbons	Known concentration of operator selected hydrocarbons	Known concentration of benzene	Known concentration of operator selected hydrocarbons
Carrier gas	NA required	UHP Nitrogen @ 50 psi incoming pressure	UHP Nitrogen @ 50 psi incoming pressure	UHP Nitrogen @ 50 psi incoming pressure	NA required
Span manifold (optional)	Built in span / sample manifold for automatic span. Available for samples below 60° C	Heated sample / span manual selector module available	Built in span / sample manifold for automatic span. Available for samples below 60° C	Built in span / sample manifold for automatic span. Available for samples below 60° C	Built in span / sample manifold for automatic span. Available for samples below 60° C

* 100% H2 or 40% H2 / 60% He (other mixtures possible, contact factory)

TELEDYNE ANALYTICAL INSTRUMENTS

A Teledyne Technologies Company

16830 Chestnut Street
City of Industry, California 91748, USA

TEL: 626-934-1500 or 888-789-8168
FAX: 626-934-1651 EMAIL: ask_tai@teledyne.com

www.teledyne-ai.com

Warranty

Instrument is warranted for 1 year against defects in material or workmanship

NOTE: Specifications and features will vary with application. The above are established and validated during design, but are not to be construed as test criteria for every product. All specifications and features are subject to change without notice.



www.thomsongroup.com.au